

# T260

## MANUAL MIDI OPERATOR

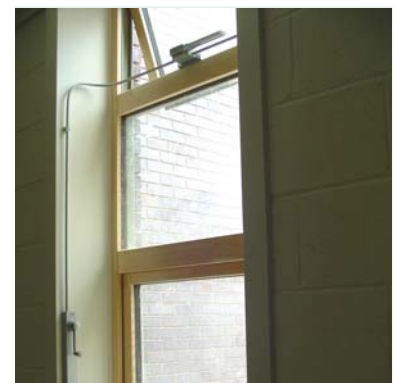

### ■ DESCRIPTION

- Midi Operator used to manually wind Open or Close high level windows or louvres.
- A single Midi Operator can be used to control individual or multiple T150, T175 or T190 Manual Openers.
- Maximum opening of 380mm (adjustable)
- Supplied complete with T275 Handle, T411 Spent Travel Tube and T720 Brass Stop.

### ■ OPENING STROKE

- 250mm (see T260 Datasheet)
- 380mm

### ■ COLOURS

- White (RAL 9010)
- Black (RAL 9005)
- Silver (RAL 9006)

### ■ WINDOW TYPES

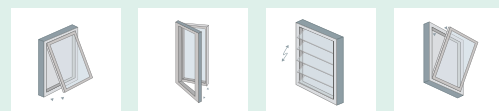

# TECHNICAL DATA

CODE	STROKE	COLOUR	MAX. WINDOW WIDTH	OPENER
T260NTB	380mm	BLACK (RAL 9005)	< 1m	T150 / T175 / T190
T260NTG	380mm	GREY (RAL 9006)	< 1m	T150 / T175 / T190
T260NTW	380mm	WHITE (RAL 9010)	< 1m	T150 / T175 / T190

## ACCESSORIES

CODE	DESCRIPTION
T250FIXINGKIT*	Fixing Kit*
T275B*	Replacement Handle Black*
T275G*	Replacement Handle Grey*
T275W*	Replacement Handle White*
T270W	Large Grip Handle White
T411*	Spent Travel Tube*
T720*	Brass Stop*

\*Supplied complete with T260 as standard.

## DIMENSIONS

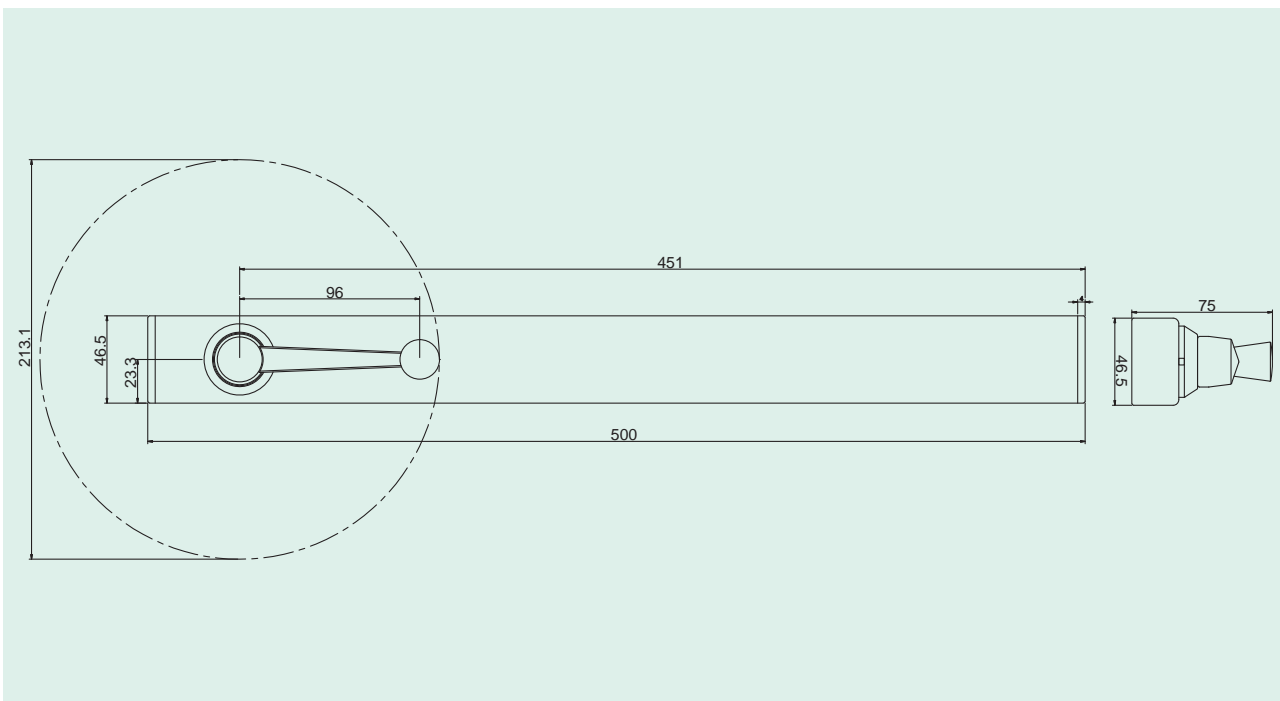

## DESCRIPTION

- Minimum window height for full 250mm opening of T100 Chain Opener = 500mm
- Minimum window height for full 380mm opening of T150 Chain Opener = 900mm
- Chain Openers fitted on windows less than recommended height must have opening restricted to 30% of the vent height using the T700 Spring Stop or T720 Brass Stop to shorten the cable run. Use only T200, T210, T260 or T300 Operator with the T150 Chain Opener (380mm).
- For safety reasons we recommend fitting side support stays to all bottom-hung, open-in windows. For bottom-hung applications you must fit the T850 fixing kit.

## MAXIMUM CONTROL RUN

OPERATOR	MAXIMUM CONTROL RUN
T200	30 Metres
T210	30 Metres
T250	18 Metres
T260	18 Metres
T300	18 Metres

## SPENT TRAVEL CONDUIT

- To allow for the forward/backward movement of the inner cable a length of "spent travel" conduit must be fitted at either end of the control panel i.e. past the last Opener and below the operator (except the T250 & T260 Midi Operators which have an integral "spent travel" tube).

OPENER	SPENT TRAVEL
SJ138600	2500mm
T100	300mm
T150	450mm

## NO. OPENERS PER VENT

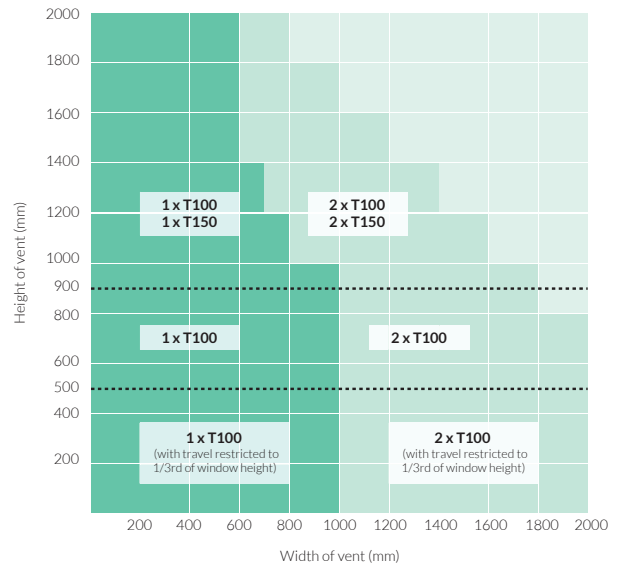

## TYPE OF OPERATOR

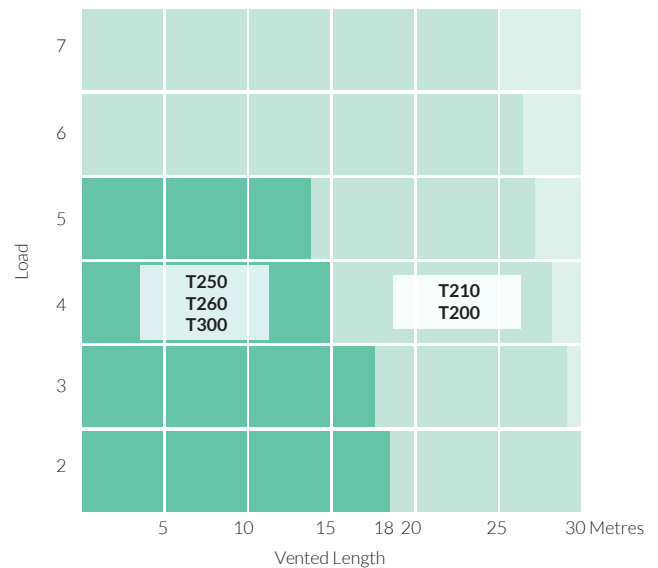

- "Load" = No. Openers + No. Bends in Conduit

The above figures are based on a single bend in the conduit path. For each additional bend deduct 1 metre from the 'Vented Length' total.

The figures used in these charts are based on windows with 4mm double glazed units fitted to butt hinges or free pivots, not friction stays. Please refer to our sales team for advice if friction stays are fitted.

# APPLICATION

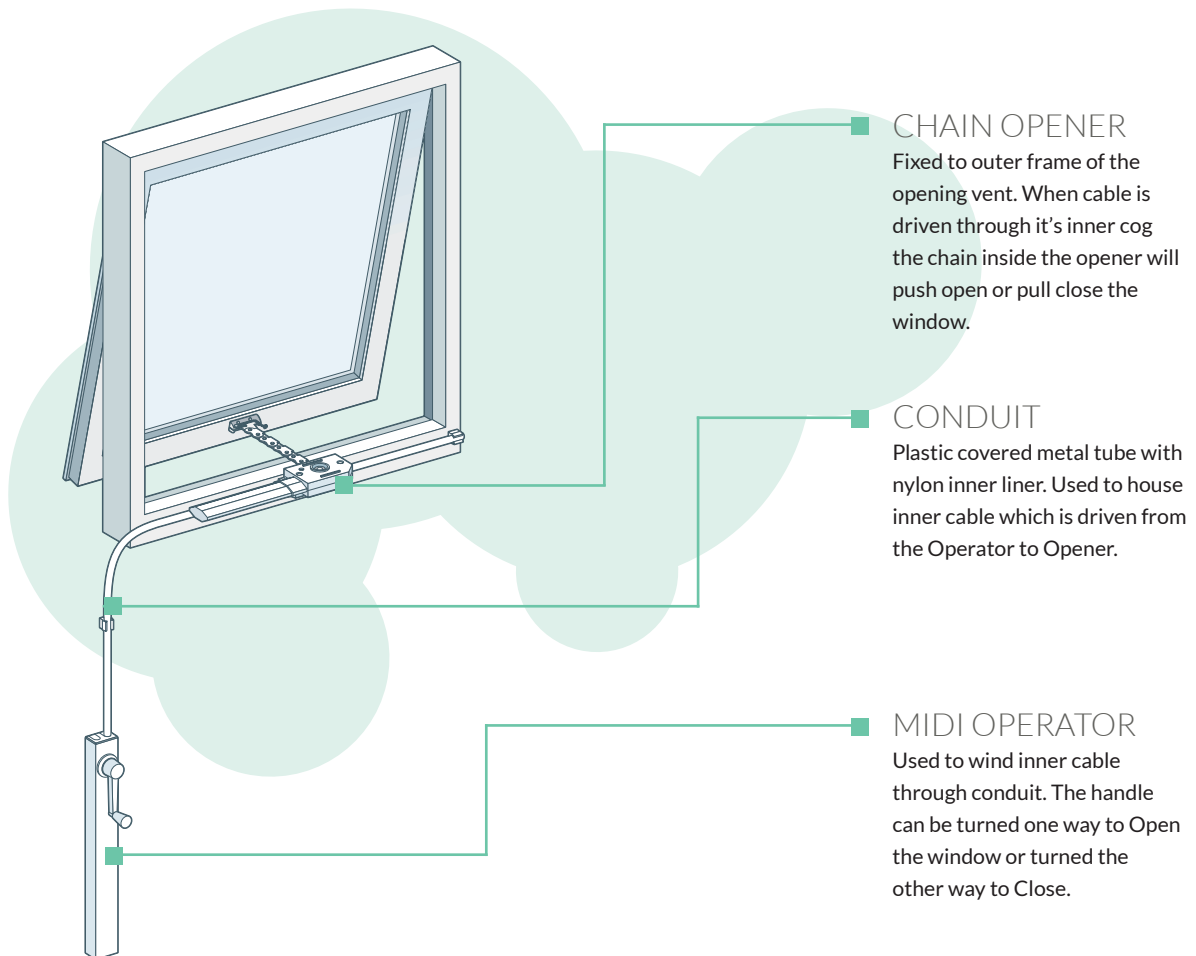

## EXAMPLES

