

WLA 330

Wind/Rain sensor

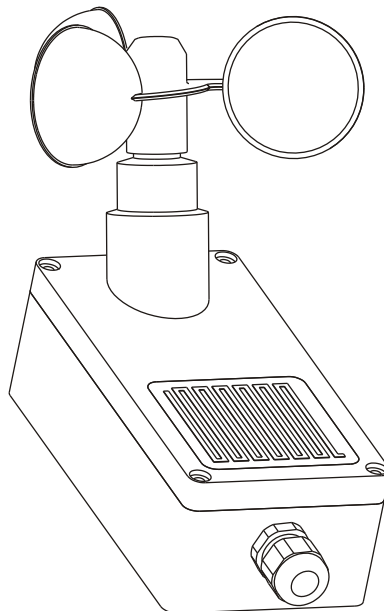

DK +45 4567 0300
UK +44 (0) 1536 614 070
DE +49 (0) 40 87 409 -560 Vertrieb / -484 Technik
CH +41 (0) 62 289 22 22
Other markets +45 4567 0300

info.dk@windowmaster.com
info.uk@windowmaster.com
info.de@windowmaster.com
info.ch@windowmaster.com
info@windowmaster.com



www.WindowMaster.com

Important information

- Read instructions carefully before installation. Keep the instructions for future reference.
- Sensor WLA 330 should be installed in accordance with current national legislation.
- Disconnect from mains supply before installation or removal of the sensor and before carrying out any maintenance or service work and ensure that it cannot be reconnected unintentionally during this time.
- If the sensor gets activated, the window operator automatically closes the window. For personal safety, never have your hand or body out of the window without disconnecting from mains supply.
- Do not paint or lacquer the rain sensor.
- Dirt on the sensor may cause operating problems. Therefore, it is recommended to clean the rain sensor with a soft wet cloth once or twice a year or when required.
- Electrical products must be disposed of in conformity with national regulations for electronic waste and not with usual household waste.
- The packaging can be disposed of with usual household waste.
- WLA 330 is a low-voltage product that complies with the requirements of the EMC directive concerning use in household, trade and light industry.
- This product has been designed for use with genuine WindowMaster products. Connection to other products may cause damage or malfunction.

Description

The wind/rain sensor comprises a wind wheel and a rain sensor surface.

This sensor is used for the automatic control of Smoke Control Units and ventilation central units.

The wind/rain sensor is equipped with a potential free change-over contact having a contact rating of 60V/2A.

In the event of wind and/or rain, the change-over contact switches over from the N/C contact to the N/O contact.

The settings for the wind trigger threshold, the actuation delay, the drop out delay and the trip in the event of a mains failure are made by a 6 pole DIP switch in the sensor.

Operation / Function

Triggering by wind

The potential free contact switches when the (settable) wind sensor trips. The red LED in the sensor is lit.

Remark:

The trip is reset 10 or 20 min. (settable) after the last sensor actuation.

Beaufort table:

Wind force in Beaufort	Speed in m/s	Speed in km/h	Wind intensity	Effects
0	0 – 0,2	< 1	calm	smoke rises straight
1	0,3 – 1,5	1 – 5	light air	only noticeable from the smoke
2	1,6 – 3,3	6 – 11	light breeze	noticeable on the face
3	3,4 – 5,4	12 – 19	gentle breeze	thin twigs are moved
4	5,5 – 7,9	20 – 28	moderate breeze	thin branches are moved
5	8 – 10,7	29 – 38	fresh breeze	small trees sway
6	10,8 – 13,8	39 – 49	strong breeze	thick branches are moved
7	13,9 – 17,1	50 – 61	moderate gale	entire trees are in motion
8	17,2 – 20,7	62 – 74	fresh gale	Branches break off trees
9	20,8 – 24,4	75 – 88	strong gale	minor damage to houses
10	24,5 – 28,4	89 – 102	whole gale	trees blown over
11	28,5 – 32,6	103 – 117	storm	severe storm damage
12	> 32,6	> 117	hurricane	

Triggering by rain

The potential free contact switches when the rain sensor trips.

The red LED in the sensor is lit.

Remark:

The trip is reset 10 or 20 min. (settable) after the last sensor actuation.

Operating/control and display elements

For assembly, remove plug connection from the cover.
Do not mismatch during assembly.

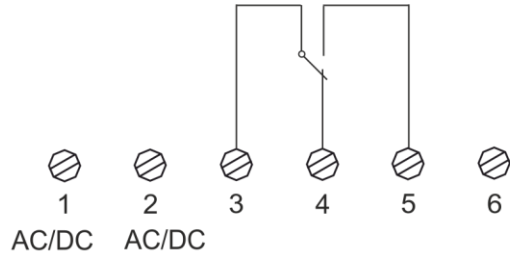
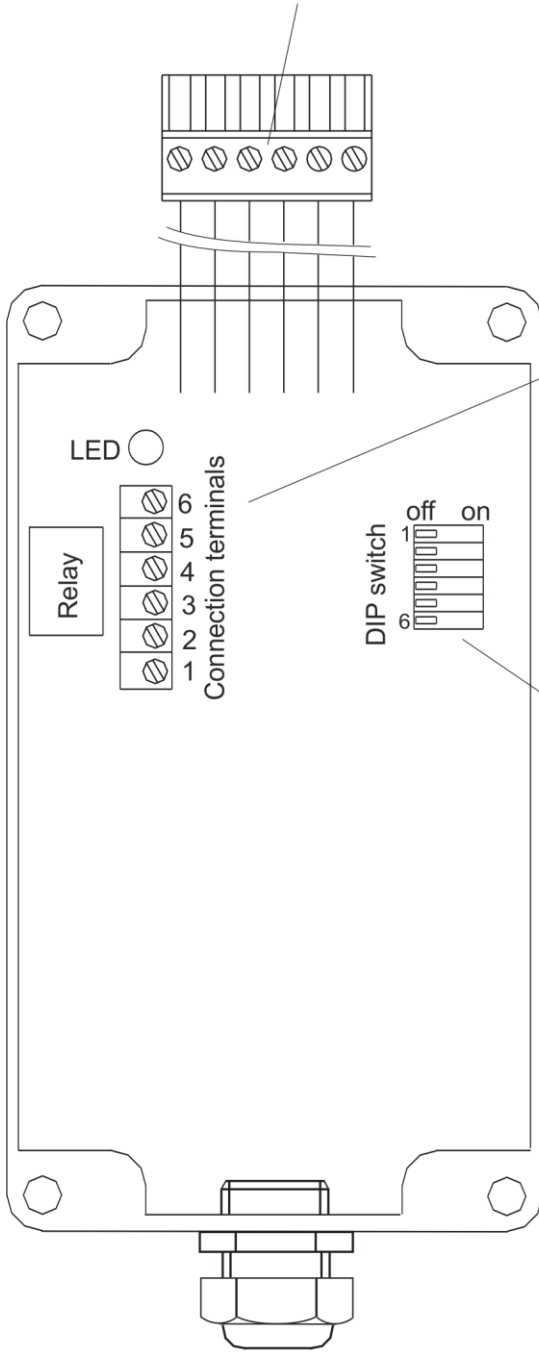

- Terminal 1 = Supply voltage AC/DC
- Terminal 2 = Supply voltage AC/DC
- Terminal 3 = Relay (arm)
- Terminal 4 = Relay (N/C contact)
- Terminal 5 = Relay (N/O contact)

Terminal 6 is internally connected to terminal 2.

Connection (DIP switch 6 = off)

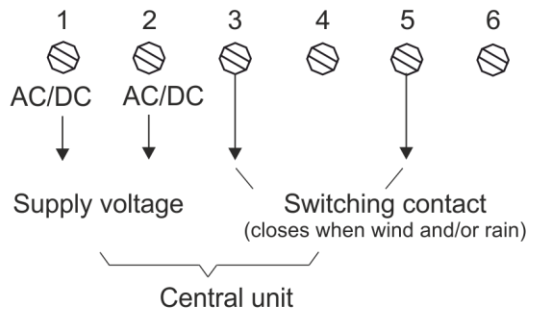

Connection (DIP switch 6 = on)
automatic trip in the event of a supply voltage failure

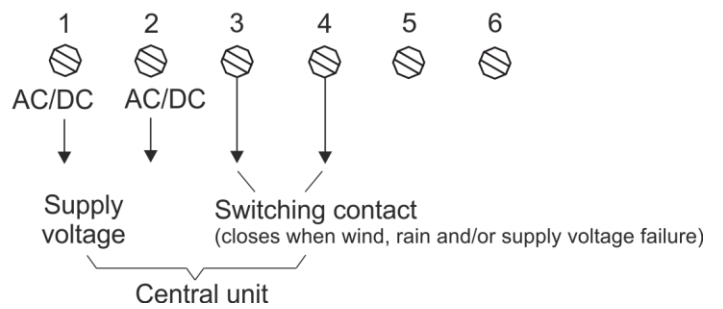

Connection to control units

WUC 102

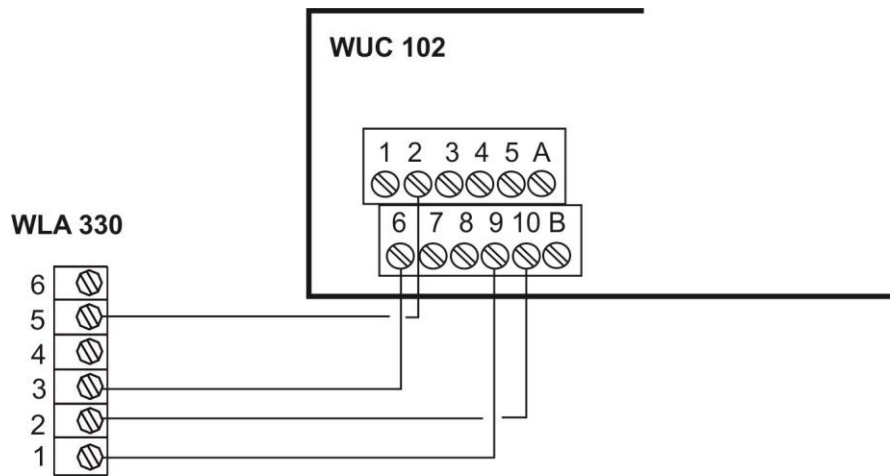

WUC 160

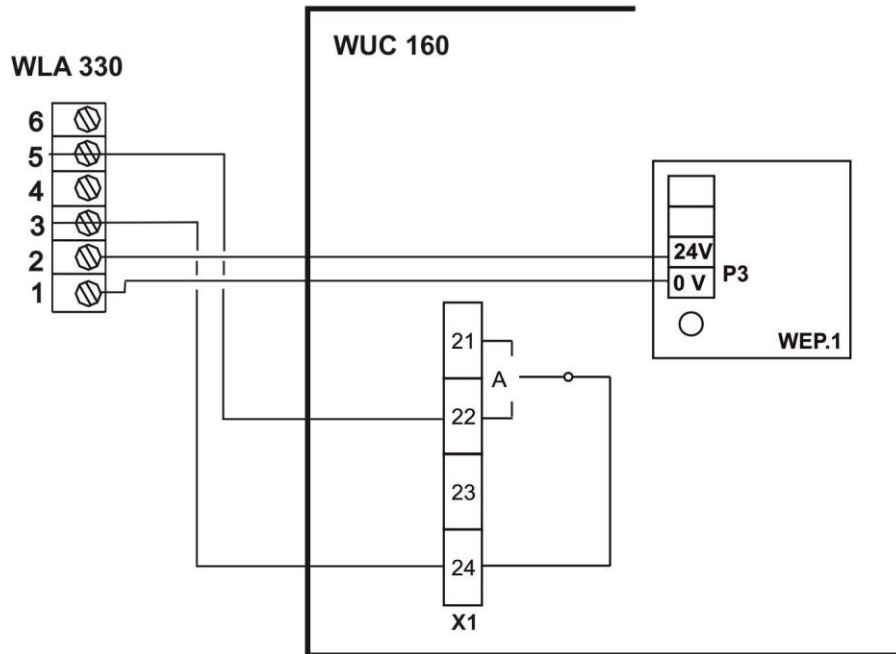

WCC 3x0 Standard

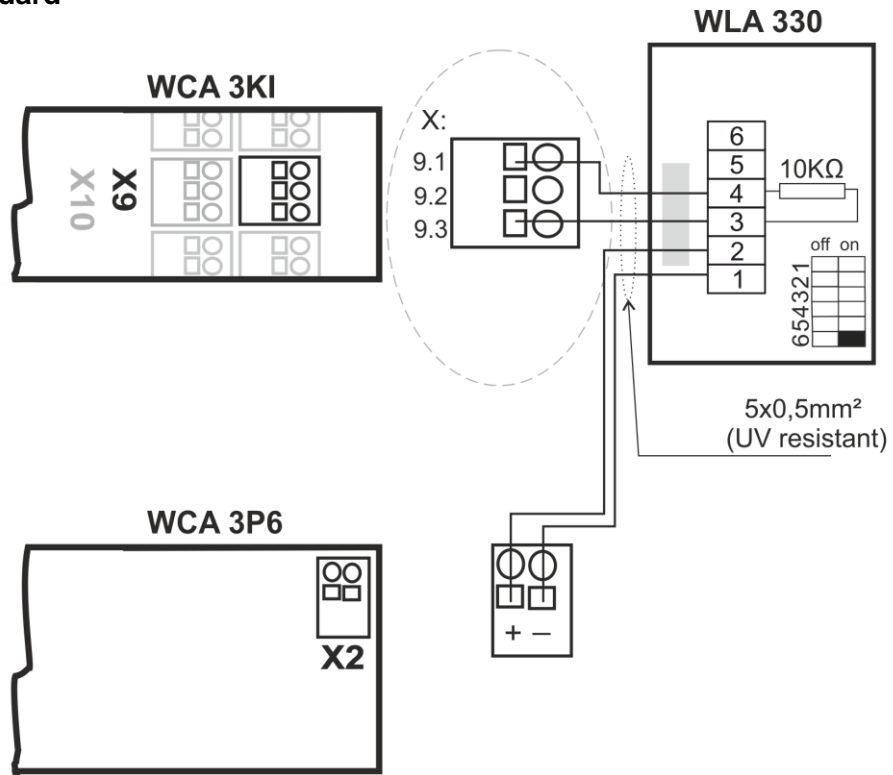

WCC 3x0 Plus

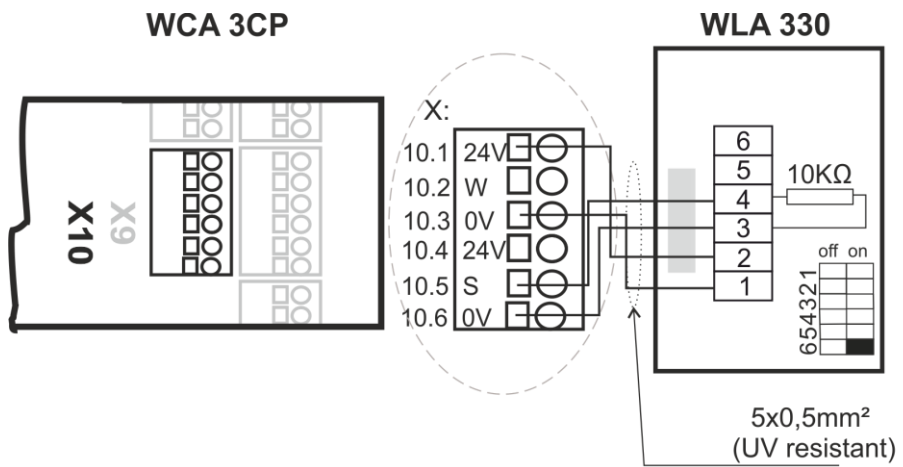

DIP switches

Various wind/rain parameters and operating modes can be set by means of the installed DIP switches.

DIP switch settings for the wind speed

	Test	Approx 3 m/s	Approx 4 m/s	Approx 6 m/s	Approx 8 m/s	Approx 10 m/s	Approx 12 m/s	Approx 14 m/s
Switch 1	off	on	off	on	off	on	off	on
Switch 2	off	off	on	on	off	off	on	on
Switch 3	off	off	off	off	on	on	on	on

Note

Factory setting = operation, meaning switch 1 = on and all other switches = off.

Should there during installation be the need to disconnect the wind/rain drop out delay, set switch 1+2+3 = off (= Test).

Important! Once installation and start-up are completed, proceed with the wind speed setting required on site, meaning one or more of the switches 1,2 or 3 MUST be on!

Remark: In the test setting, the activation and drop out delay is deactivated!

DIP switch settings

	Switch setting OFF	Switch setting ON
Switch 4 = Wind activation delay	2 seconds	5 seconds
Switch 5 = Wind/rain drop out delay	10 minutes	20 minutes
Switch 6 = Monitoring	off	on

Information regarding switch 6:

Only the supply voltage (terminals 1+2) for the sensor is monitored.
The system will trip automatically in the event of a supply voltage failure.

Display: Red steady light in the sensor LED = Sensor tripped by wind or rain.

Connection

Terminal 1 = Operating voltage AC/DC

Terminal 2 = Operating voltage AC/DC

Terminal 3 = Relay (arm)

Terminal 4 = Relay (N/C contact)

Terminal 5 = Relay (N/O contact)

Technical data

Supply voltage:	18V to 26V AC or 20V to 32V DC
Circuit output:	1 x potential free change-over contact
Switching capacity:	60V / 2A
Sensor dimensions:	80 x 160 x 55mm (WxHxD / without wind wheel)
Sensor weight:	approx. 0.7kg
Sensor protection type:	IP65
Setting of the wind mode:	approx. 3 to 14 m/s (±20%)
Setting of the wind/rain drop out delay:	10 min. / 20 min.
Setting of the wind actuation delay:	2 s / 5 s
Setting of the monitoring:	Off / On
CE sign	in accordance with the EMC directive and the low voltage directive
Cleaning	clean the sensor regularly depending on the degree of soiling.